

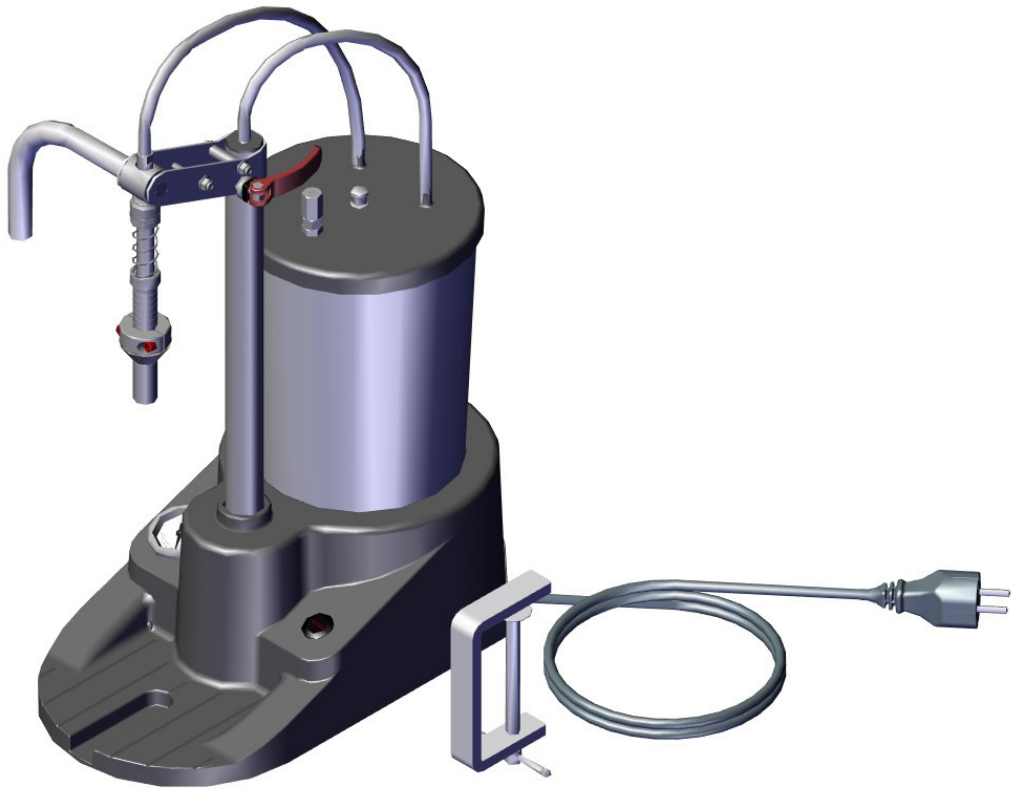

USER MANUAL
ULTRAFILLER 1 LITE



This INSTRUCTIONS FOR USE manual has been produced
in accordance with Directive 2006/42/EC

It is prohibited to reproduce it, even partially, without the prior
written authorization of ILTEC by I.L. INDUSTRIA di LEIVI Srl



Via Gazzo, 1
16040 Leivi (GE)
T. +39 338 6616740
www.il-tec.com/
sales@il-tec.com

INTRODUCTION TO MANUAL.....	5
RETENTION OF INSTRUCTIONS FOR USE.....	5
DEVICE IDENTIFICATION DATA	5
INTENDED USE.....	6
SAFETY PRESCRIPTIONS	6
PACKAGE CONTENTS.....	8
UNPACKING.....	8
DESCRIPTION OF THE DEVICE.....	9
TECHNICAL DATA.....	9
INSTALLATION.....	10
Positioning	10
Return pipe connection	10
Delivery pipe connection	10
Electrical connection	11
ADJUSTMENT.....	12
FLUSHING	14
FILLING OF BOTTLES	15
TANK EMPTYING	16
MAINTENANCE.....	17
Pulizia.....	17
TROUBLESHOOTING	18
SPARE PARTS.....	19
DISPOSAL.....	20
DECLARATION OF CONFORMITY	20
WARRANTY.....	20

Intentionally blank page

INTRODUCTION TO MANUAL

The Instruction Manual represents the training reference document prepared by the Manufacturer, aimed at users who will come into contact with the machine throughout its life cycle.

The purpose of the document is to provide information for proper use of the equipment, from installation to disposal, highlighting the dangers that can result from incorrect use.

In order to achieve good results in the installation environment, the instructions given in this Manual should be strictly followed, avoiding, above all, the occurrence of technical problems and the exposure of operators to health hazards.

The following symbology is used within the User's Manual to indicate the presence of hazards and draw the reader's attention to important information:

NOTE

The important notation to be highlighted is inserted in this area.

CAUTION

Indicates a reminder to apply safety practices or calls attention to unsafe practices that could cause personal injury or damage to the machine or components or the environment.

WARNING

Indicates that there is a danger that may cause injury or death if appropriate precautions are not taken.

RETENTION OF INSTRUCTIONS FOR USE

NOTE

This user's manual is an integral part of ULTRASEAMER tumblers and should be read carefully before use as it provides important guidance regarding safe installation, operation and maintenance.

Therefore, keep it carefully.

ATTENTION

Failure to follow the instructions below is a dangerous condition and puts the proper operation of the equipment at risk.

ATTENTION

Before using ULTRASEAMER lattiners, carefully read the general safety rules below.

DEVICE IDENTIFICATION DATA

The manufacturer's identification and European Directive conformity plate is located on the device.

Several safety warnings are applied to the device; such warnings must be strictly followed by everyone dealing with the product. The company is not to be held responsible for damage to property or accidents to people which might occur if the above-mentioned warnings are not observed. In such a case, the operator is the only person responsible.



INTENDED USE

The Ultrafiller filling machine is intended for the semiautomatic filling of bottles with liquid foods.

It can be used for:

- Beer
- Wine
- Vinegar
- Cider
- Fruitjuices
- Non viscous liquids

No liability will be assumed if other kinds of liquids or solvents are used.

WARNING

The maximum liquid temperature must be lower than 60°C.

ATTENTION

It is absolutely forbidden to make any changes to any component of the product or replace it with non-original parts.

WARNING

Uses of the product not in accordance with what is described in this document are considered improper and therefore declared unsafe.

Such unintended uses may result in damage to the equipment and personal injury, including serious injury. Any other use other than that for which the product was designed and described in this document is considered non-compliant, and therefore the Manufacturer disclaims all liability.

NOTE

ILTEC by I.L. INDUSTRIA di LEIVI Srl shall not be held liable in the event of damage to the machine and/or injury to personnel due to failure to comply with the safety requirements set forth in this Manual.

SAFETY PRESCRIPTIONS

WARNING

Read all the instructions and safety warnings before use. Keep the manual for future reference.

- After removing the packaging make sure of the integrity of the device. If in doubt, do not use them and contact ILTEC by I.L. INDUSTRIA di LEIVI Srl. Do not leave any packaging items (plastic bags, cardboard, etc.) within reach of children or disabled persons as they are potential sources of danger. The safety concept of the appliance is only valid in perfect condition.
- This equipment is not designed to be used by persons (including children) with reduced physical, physiological or intellectual capabilities, or who lack experience and/or ability, unless they are under the supervision of a person responsible for their safety or providing them with instructions on how to use the equipment.
- Check that the power cable is intact before use. If not, contact customer service.
- Check that the plug fits the socket before use. If not, contact customer service.
- Do not plug or unplug with wet hands.
- Place the device on a dry and stable surface.
- To ensure sufficient ventilation, leave at least 12 cm of clearance around the device.
- Do not expose the device to direct sunlight, to wind, rain and splashing water.
- Do not obstruct the device with objects when it is in operation.
- Disconnect the plug from the outlet before cleaning the device-otherwise you risk electric shock or death.
- Do not use metal sponges or abrasive products to clean the device.
- Supervise children so that they do not play with the ULTRASEAMER.
- The device is for use in the home and similar environments (workplaces, hotels, motels, and similar facilities). The device is not for industrial use.

- Entrust customer service to repair or replace damaged or malfunctioning connection cables and/or devices.
- Do not open the casing of the device to try to repair it yourself. Doing so may compromise the safety of the device and void the warranty.
- NEVER immerse the device in water or other liquids; clean it only with a slightly damp cloth.
- Never leave the device switched on.
- Use the device in environments with temperature between 10°C and 35°C.
- Keep hands away from moving parts when operating the device.
- Do not use the device if it is damaged.

ATTENTION

The original configuration of the equipment must not be changed at all. Upon receipt of the same, check that the delivery corresponds to the order specifications. In case of nonconformity inform the manufacturer immediately.

Also check for damage during transport.

WARNING

Leivi's Industria products are not designed to operate in explosive and high fire hazard environments. In case of failure or improper operation, the equipment should not be used until the Technical Service Department has completed repair work.

NOTE

This manual is an integral part of Ultrafiller filling machines and it must be carefully read before using it since it gives important indications with regards to its safe installation, use and maintenance. Keep it with care.

ATTENTION

Failure to comply with the following instructions will result in dangerous conditions which may affect personnel safety and machine operation.

PACKAGE CONTENTS

The device comes in a box inside which are contained:

1. Ultrafiller filling machine
2. Product delivery pipe
3. Clamp
4. O-ring set for nozzles
5. Socket head screw for shaft collar adjustment

OPTIONAL

- Cartridge station (cartridges h=10")
- Mignon nozzle with assembly instructions
- Oil bath filter

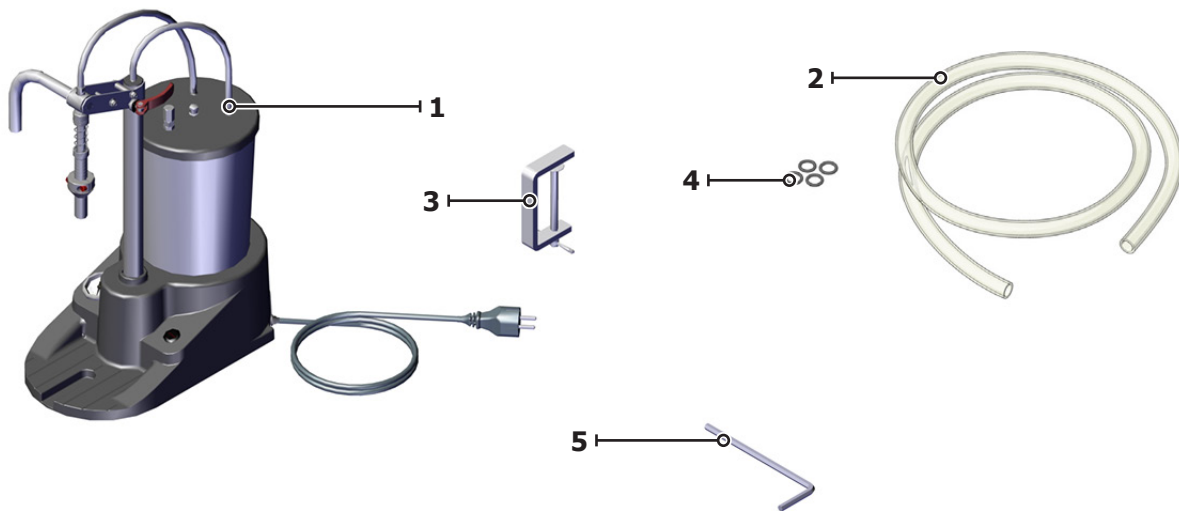

UNPACKING

1. Remove the device from the box.
2. Remove all the components from the box.
3. Check the package contains all the components listed above.
4. Before using the device, check that all of the items listed have been delivered and that there are no visible signs of damage.

WARNING

Don't let children play with plastic bags.

They risk choking on them.

DESCRIPTION OF THE DEVICE

- The device consists of the following main components:
- | | |
|------------------------------|----------------------------|
| 1. Nozzle holder bracket | 5. Vacuum adjustment valve |
| 2. Filling nozzle | 6. Product supply pipe |
| 3. Vacuum gauge | 7. Power cable |
| 4. Tank for liquid discharge | 8. ON/OFF switch |

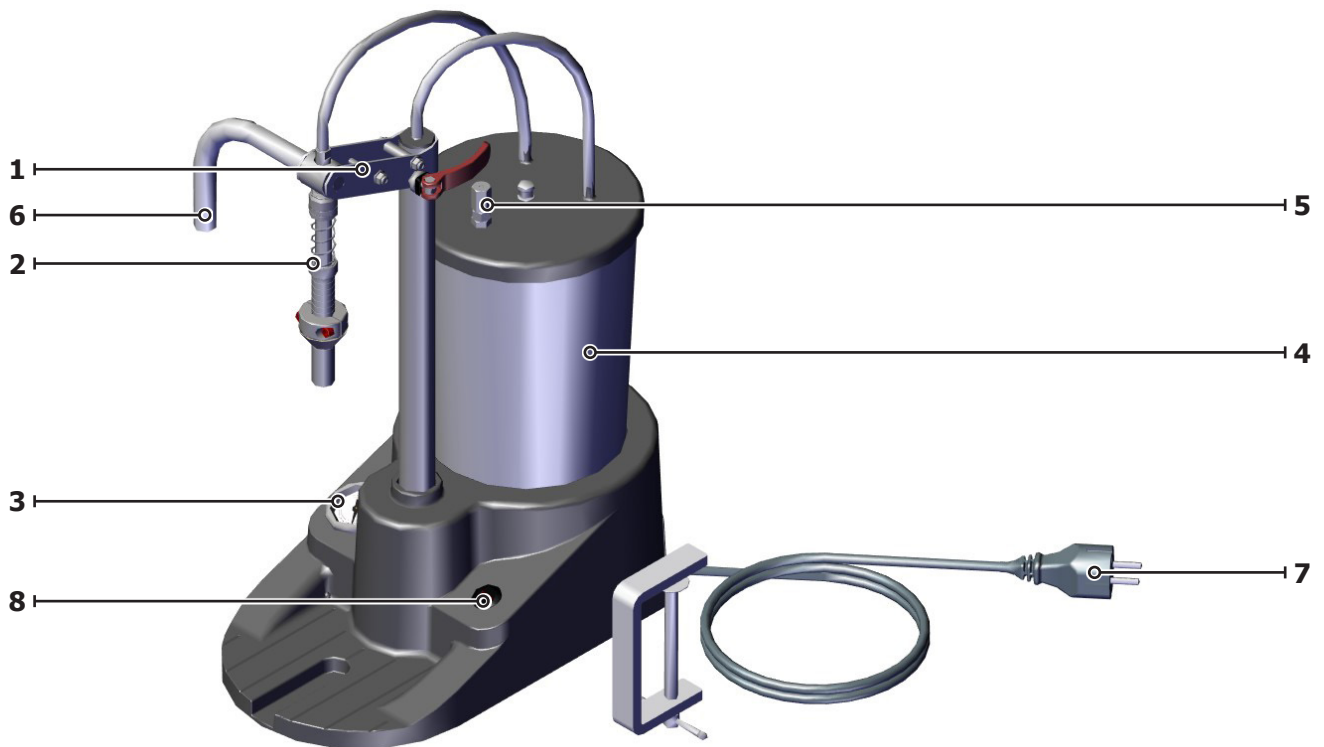

TECHNICAL DATA

MODEL	ULTRAFILLER 1
Number of nozzles	1
Power supply	110V 60 Hz o 230V 50 Hz
Dimensions	200x485x420
Weight	3,5 kg
Degree of protection	IP20

INSTALLATION

Positioning

Place the filling machine on a flat surface, away from heating sources.

Make sure the machine is properly levelled. If not, adjust it.

Place the tap in its seat on the tank.

Return pipe connection

Connect the supplied return pipe to the proper pipe holder.

ATTENTION

Check the position of the pipes which have already been installed on the machine to prevent liquid and air spillages.

Make sure the tank for liquid discharge is in its correct position.

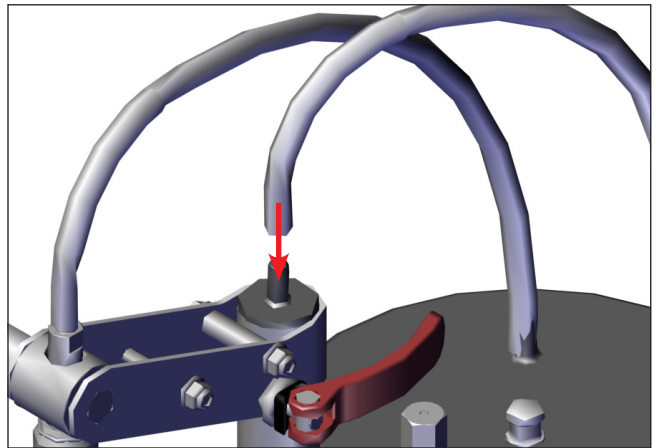

Delivery pipe connection

Connect the supplied delivery pipe to the proper pipe holder.

ATTENTION

Check the position of the pipes which have already been installed on the machine to prevent liquid and air spillages.

Make sure the tank for liquid discharge is in its correct position.

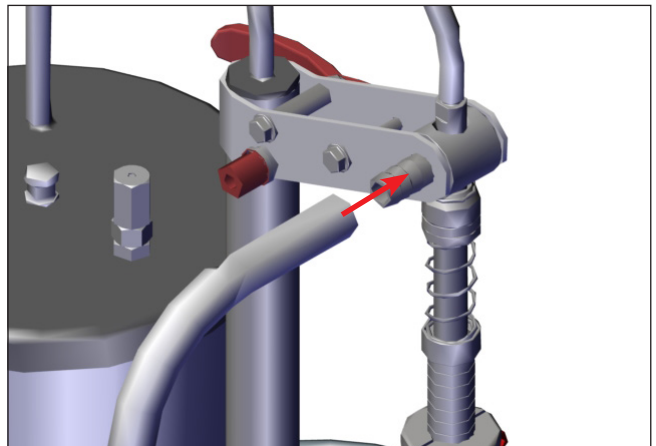

Electrical connection

ATTENTION

Before connecting the device to a voltage source, check that its voltage matches that indicated on the device's nameplate data and that the power switch is in the "0" position.

Connect the device to the power supply by means of the cable [1] provided.

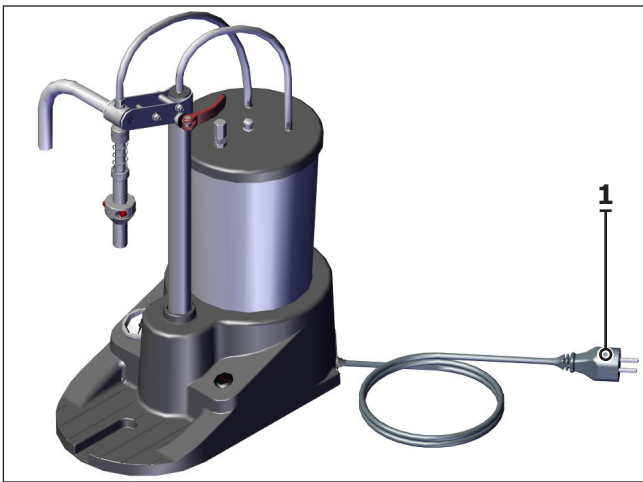

WARNING

Before using the filling machine, carry out the flushing operations described in chapter 9 "Flushing".

No liability will be assumed if flushing is not carried out to remove dusts which could affect the quality of the bottled product.

ADJUSTMENT

NOTE

The adjustment points on the filling machine are marked in red in the pictures. Do not adjust other parts of the device.

- Open the lever [1] and lift the nozzle support unit [2] completely, then tighten it.

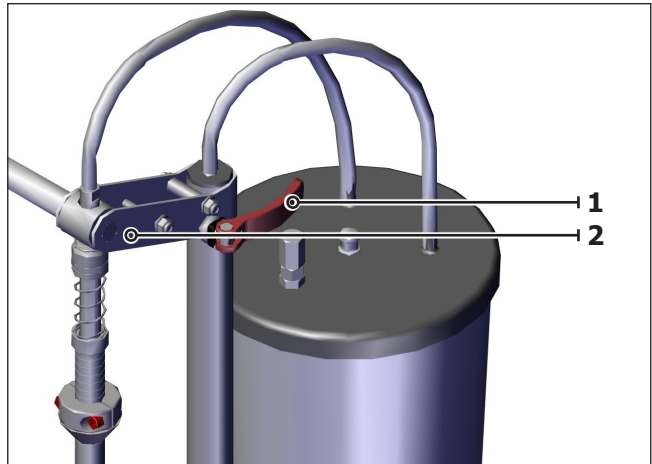

- Put a bottle under one of the nozzles.

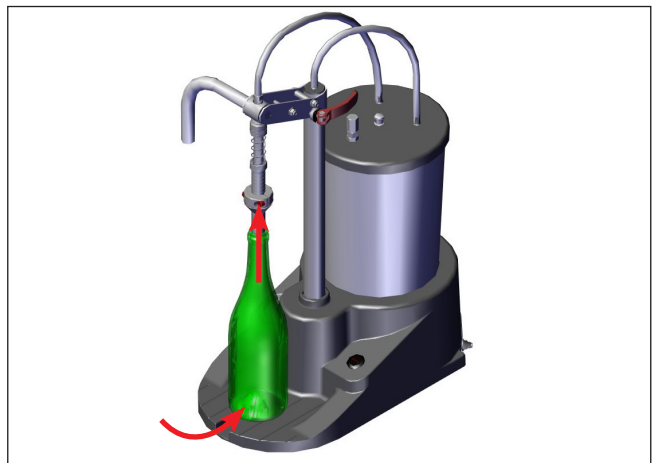

- Open the lever [1] and lower the nozzle support unit [2] until reaching piston [3], then close the lever [1].

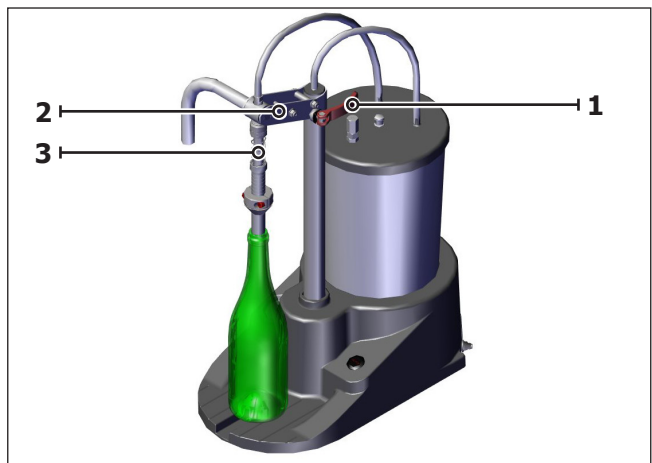

- To change the maximum level of liquid in the bottle, change the position of collar [4] after loosening Allen screws [5]. If the collar is not properly attached to the nozzle, use the provided hexagonal wrench to tighten it. By lowering the collar, the filling level can be raised, while by lifting it, it can be lowered. By moving the collar, it could be necessary to repeat the adjustment in the previous point.

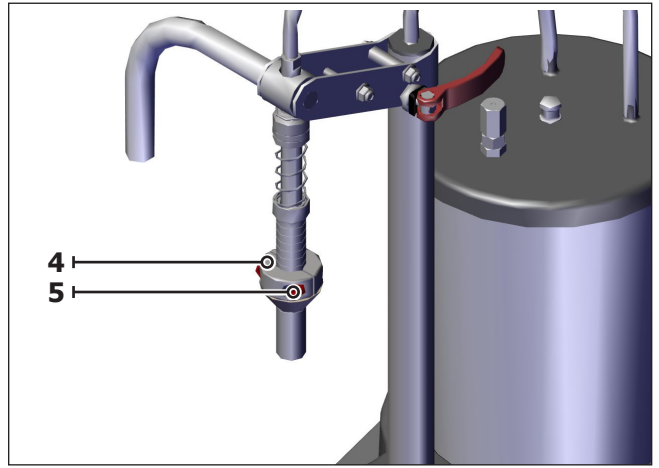

- Adjust the bottle filling speed by means of valve [6]. The maximum filling speed is reached when the valve is completely closed. To reduce such speed, unscrew valve [6]. The recommended reference pressure is 0,3-0,4 bar.

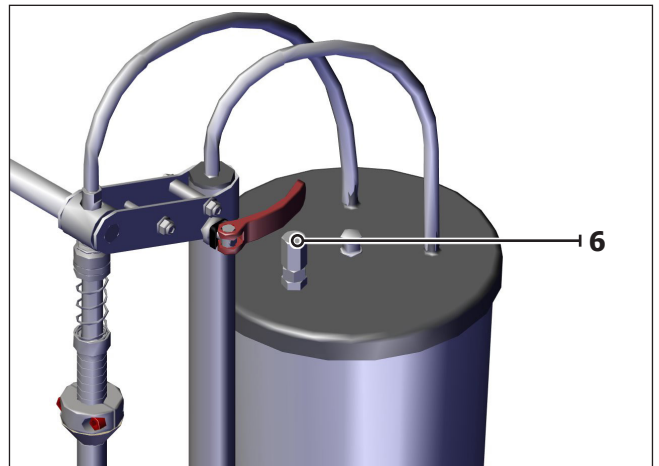

- This valve allows changing of the suction (vacuum) pressure value during the filling phase. This value can be read through the vacuumeter [7] located on the front part of the filling machine.

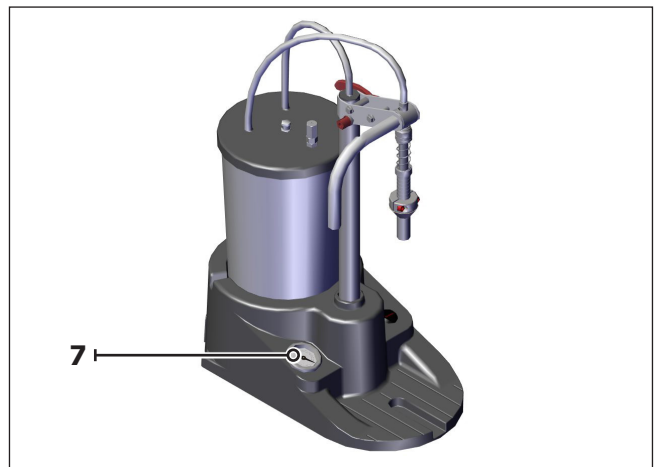

NOTE

To carry out the flushing operation, valve [6] must be completely closed (maximum flow rate).

- Make the nozzle rotation softer or harder by means of screw [8].

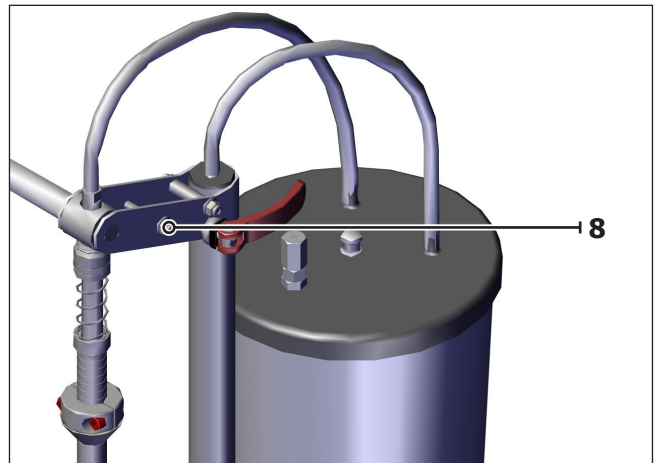

FLUSHING

Before using the filling machine with the desired product, flush it by using drinkable water at room temperature. The use of a sanitizer is also recommended.

This operation allows any dirt or residues to be removed from pipes, ensuring the good quality of the processed product.

WARNING

Do not use soaps and/or foamy products. Do not use acids.

- Put delivery pipe [1] into a tank containing water at room temperature.
- Turn the filling machine on by pushing the proper button.
- Carry out the proper adjustments as shown in chapter "Adjustment".
- Put a bottle under the nozzle and fill it checking that a part of the liquid is discharged into the collection tank.
- Carry out several fillings to make sure water passes through each pipe.

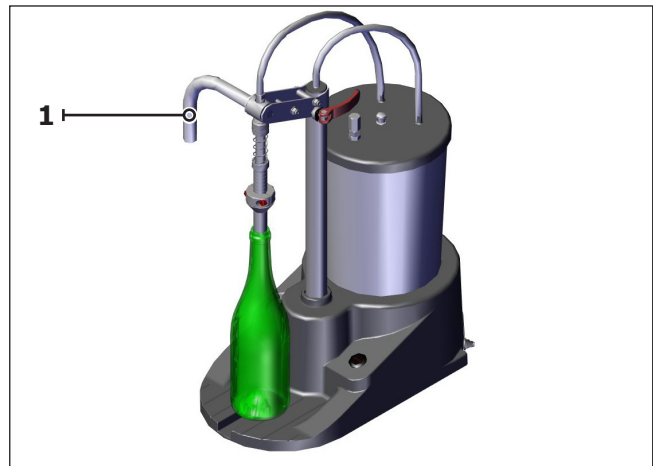

NOTE

Inside the tank there is a float that stops the filling machine operation when the maximum level is reached.

Make the tank reach room pressure by raising the float placed on the tank.

At the end of the flushing operation, empty the tank.

FILLING OF BOTTLES

After carrying out the necessary adjustments and the flushing, it is possible to fill bottles.

- Make sure the collection tank is completely empty.
- Follow the points in paragraph "Flushing" placing pipe [1] in the tank containing the fluid to be transferred.
- Turn the ON/OFF switch to 1.
- Place an empty bottle under the nozzle. After reaching the set level, the product will flow automatically to the collection tank. Remove the bottle to avoid product waste.
- Put the next bottle.



WARNING

Place the bottle carefully to prevent it from being damaged.

NOTE

Check each bottle visually to make sure it did not chip accidentally during its filling.

WARNING

At the end of each use, carry out flushing with drinkable water at room temperature (refer to paragraph "Flushing").

TANK EMPTYING

In the collection tank there is a float which stops the filling machine operation if the maximum level is reached.

In such a case, it is necessary to empty the tank by doing as follows:

- Turn the filling machine off by pushing the ON/OFF switch.
- Remove vacuum from the system by reasing the float.
- Remove the **cover**, take out the tank and empty it.
- Put the tank back in its original position.



MAINTENANCE

Pulizia

ATTENTION

Before carrying out any intervention, make sure vacuum is eliminated by the system (vacuum indicator shows "0" bar) and that the filling machine is disconnected from the power supply.

At the end of each use, it is necessary to remove any product residue through flushing with water (see chapter "Flushing").

Then clean and dry the machine thoroughly.

For a more accurate cleaning, remove the pipes and clean the manifold with a brush.

WARNING

Do not use soaps and/or foamy products.

TROUBLESHOOTING

Problem	Possible causes	Proposed solutions
The filling machine does not turn on	No power supply	Make sure the machine is supplied with power
	Incorrect electrical connection	Make sure that the power cable is properly connected
	Machine in depression	Turn the switch to 0; lift the float until the machine reaches atmospheric pressure, then make sure the vacuummeter shows "0 bar". Turn the machine on again and make sure depression occurs inside the machine.
The machine is on but the bottle is not filled	Lifted float	Empty the liquid disposal tank and turn the machine on again
	The suction pipe is not connected to the demijohn or it is connected to its bottom	Adjust the position of the suction pipe so as to keep it inside the suction tank but at a proper distance from its bottom
	The adjustment valve is completely open	Close the adjustment valve completely by turning it clockwise; after depression stabilizes, carry out the adjustment according to needs.
	Incorrect height adjustment of the nozzle support	Adjust the height of the nozzle support following the instructions provided in chapter "Adjustment"
Bottles are filled too slowly	Nozzle not properly lifted	Check the nozzle adjustment and, if necessary, adjust their height again (see chapter "Adjustment")
	The disposal tank is full	Empty the tank: turn the machine off, disconnect it from the power outlet, remove the quick release then take out the tank and empty it
	The vacuum adjustment valve is too open	Adjust the valve to obtain a correct working depression
	Chipped bottle neck	Check the bottle and, if necessary, replace it

SPARE PARTS

NOTE

For a proper operation of the filling machine, use original spare parts only.

At the customer's request they can be provided:

- pipes
- complete nozzles
- complete tank

DISPOSAL

If the figure below (the crossed-out mobile waste bin) is on the product, European Directive 2012/19/EU applies. These products cannot be disposed of with normal waste. Find out about current regulations on separate collection of electrical and electronic devices. Do not dispose of old devices with household waste. By properly disposing of old devices, you protect the planet and people's health from possible negative consequences. Recycling materials helps reduce the consumption of raw materials.



DECLARATION OF CONFORMITY



Manufacturer: Industria di Levi - Via Gazzo, 1 - 16040 Levi (GE) - Italy

It is declared that the CE-marked machine complies with the following Directives:

- 2014/30/UE EMC directive
- EN IEC 55014-1/2021 + A1/2010 + A2/2012
- EN IEC 61000-6-2/2019
- EN IEC 61000-6-3/2021 + A1/2013
- 2014/35/UE Low voltage directive
- EN 60335-1:2013 + A11/2023 + A13/2018
- 1935/2004/CE Regulations
- 2023/2006/CE Regulations
- DM 21/03/1973
- CE 10/2011

WARRANTY

The Ultrafiller filling machines manufactured by Industria di Levi have a 12 month warranty from the purchase date, except in case of different written agreements.

The warranty covers all manufacturing and material defects. Replacement and repair operations are covered only if carried out at the manufacturer workshop . If in-warranty goods need to be repaired, the customer must always send the whole Ultrafiller filling machines to the manufacturer. Single units will not be repaired under warranty.

The material to be repaired must be sent CARRIAGE FREE.

Once the machine has been repaired, it will be sent CARRIAGE FORWARD to the customer.

The warranty covers neither interventions on site by our technicians nor the device disassembly from the installation place.

They are excluded from the warranty:

- failures caused by improper use or assembly;
- failures caused by external agents;
- failures caused by neglect or poor maintenance.

The warranty is void:

- in case of delinquency or other breach of contract;
- if repairs or modifications are made to our equipment without our consent;
- should the damage be caused by misuse, as well as by mishandling such as knocks, falls, and other causes not attributable to normal operating conditions;
- should the device be found to have been disassembled, tampered with, or repaired by unauthorized personnel;
- should the equipment be used for purposes other than those specified in this manual.

Repairs made under warranty do not interrupt the duration of the warranty.

We thank you in advance for your attention to this handbook and invite you to let us know of any suggestions you feel are necessary to make it more complete.

